

MP292 Dot Matrix Printer Mechanism

Features

- Highly reliable 9-pin print head.
- High-speed printing: approx. 3.1 lines/sec.
- Includes automatic positioning function
- Two Color

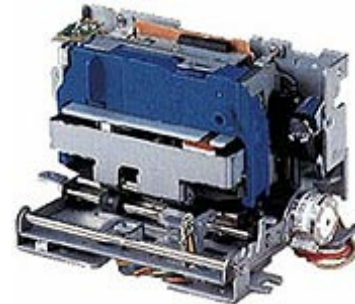

MP292

MP292

The MP292 mechanism provides OEMs/ system integrators with the flexibility of designing their own printing systems.

Specifications

| | |
|-------------------------------|--|
| Print Speed | 3.1 LPS |
| Paper Width | 80 mm – 182 mm |
| Paper Length | 80 mm – 257 mm |
| Print Width | 63 mm |
| Resolution | 72 dpi |
| Print Columns | 42 |
| Reliability | MCBF 2.5 Million Lines Print Head 70 Million Characters |
| Multiple Copies | Original + 2 Copies |
| Operating Voltage | 24V \pm 5% |
| Control Board (Option) | BD290MD-24-A |

Part Numbers

| | |
|---|----------|
| Printer Mechanism – MP292-24G-A | 39082000 |
| Control Board – BD292MD-24-A | 39209130 |
| Print Head– Flat Cable 19X205 | 30722010 |
| Power Supply – PS60-L-24A | 30781440 |
| Control Panel – Board Unit | 37307210 |
| Ribbon Cassette – RC200B (Black) | 30980112 |
| RC200BR (Black & Red) | 30980211 |
| RC200P (Purple) | 30980012 |

External Dimensions

MP292-24G

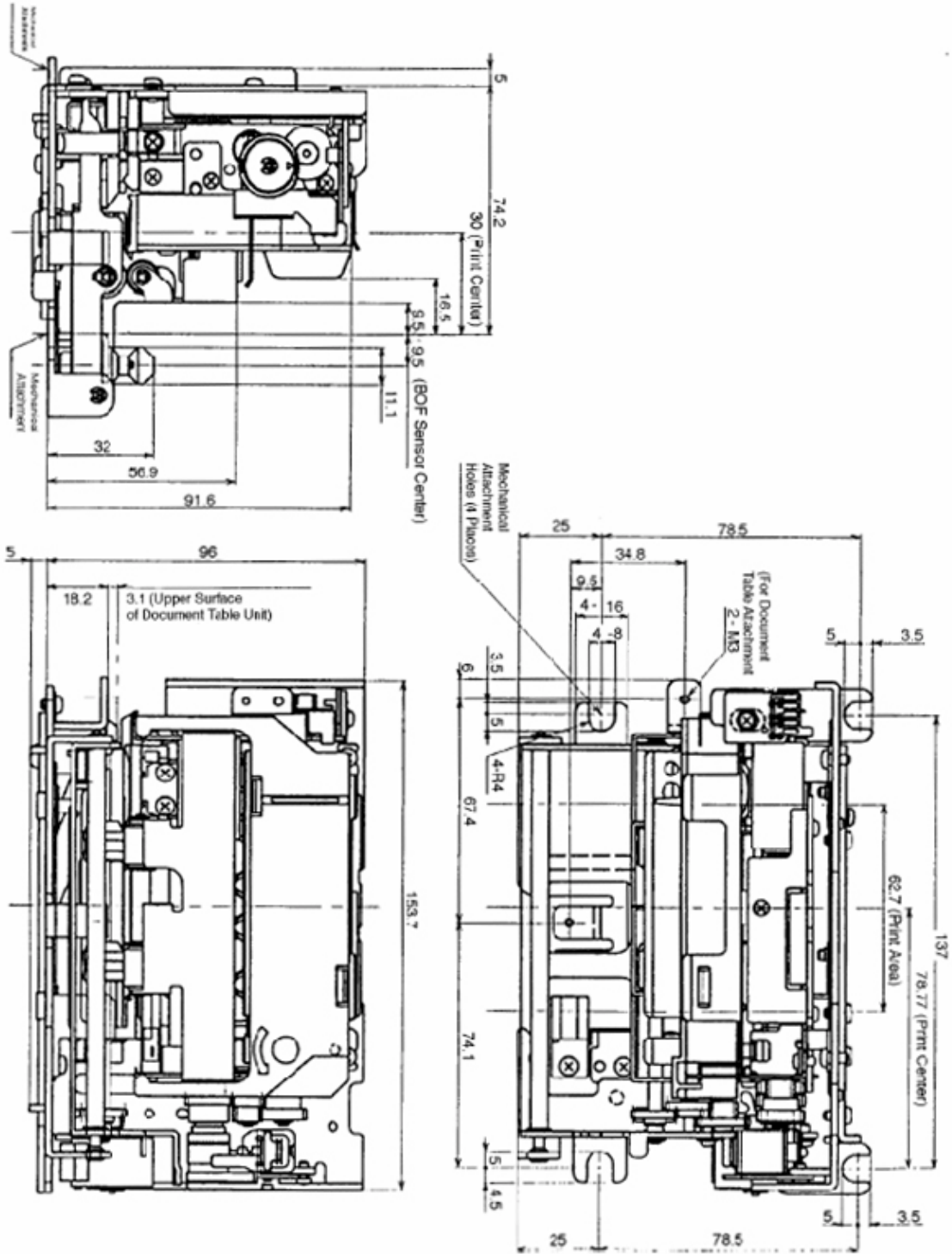

BD290 Dimensional Drawing

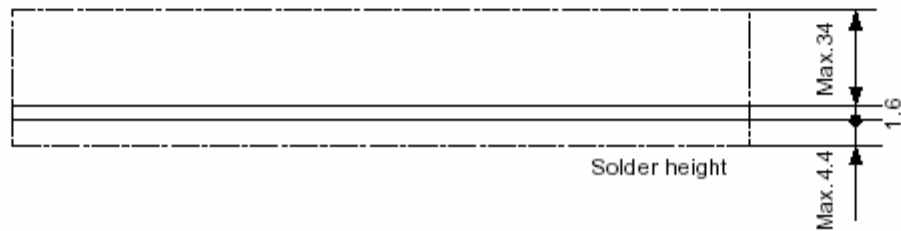
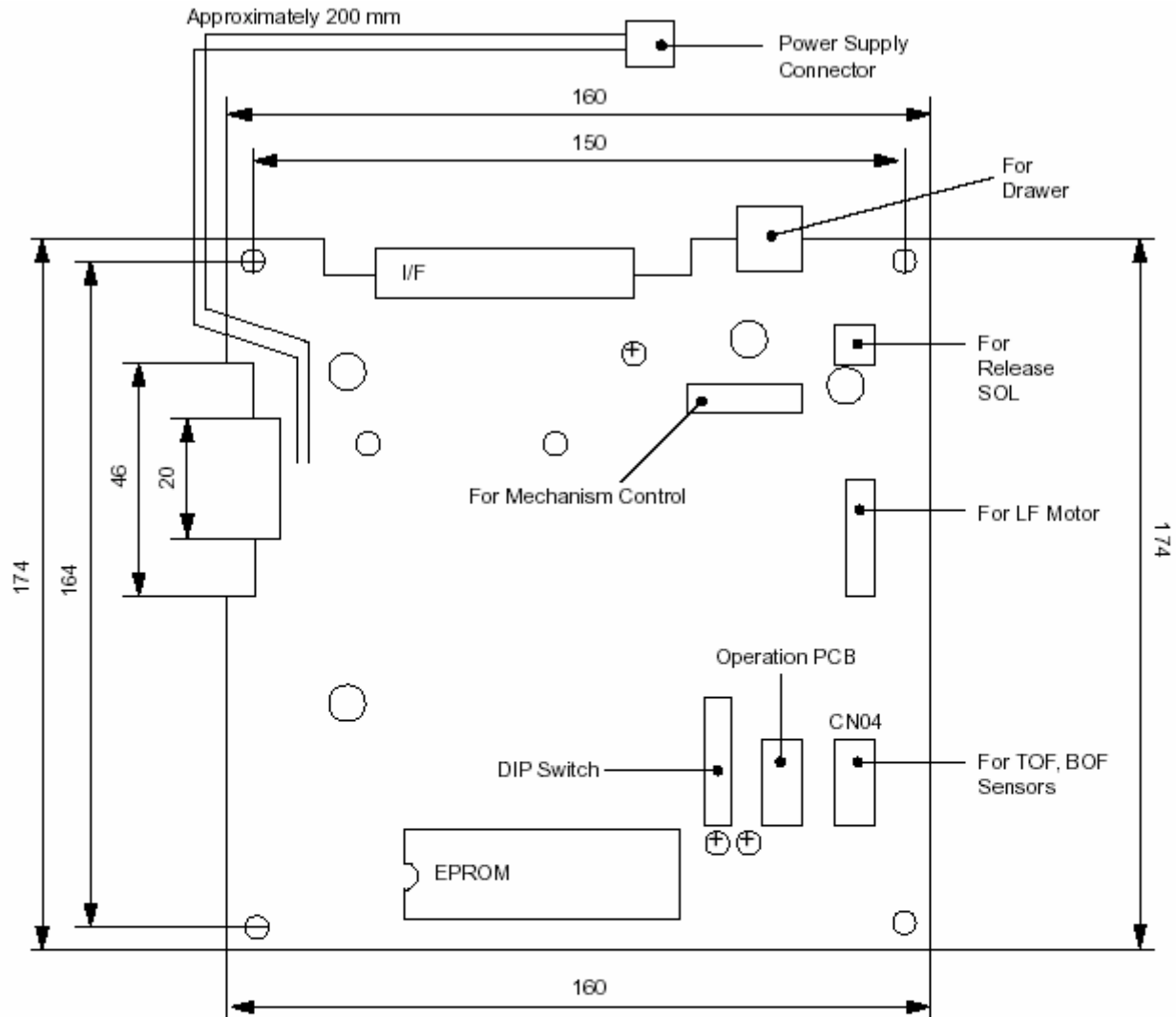

Unit : mm